



VAXIS · ATOM 500 SDI

Wireless Video System

To Our Vaxis Customers:

Thank you for your recent purchase of the Vaxis Atom 500 SDI. We created this product with you in mind and hope you will find the Atom 500 SDI useful.

Features

- 500 feet transmission system
- <0.1s latency
- Enclosed Antenna Design
- HDMI input and SDI input
- Support USB-C voltage input
- iOS & Android App support
- Support smart option
- Future Firmware Upgrades via USB
- Smart fan
- OLED display screen
- Stable & Reliable industrial metal housing

Applications

- Indie filmmaking
- Live broadcasting
- Sports
- Educational videography
- Wedding videography
- Corporate / event videography

Packing list

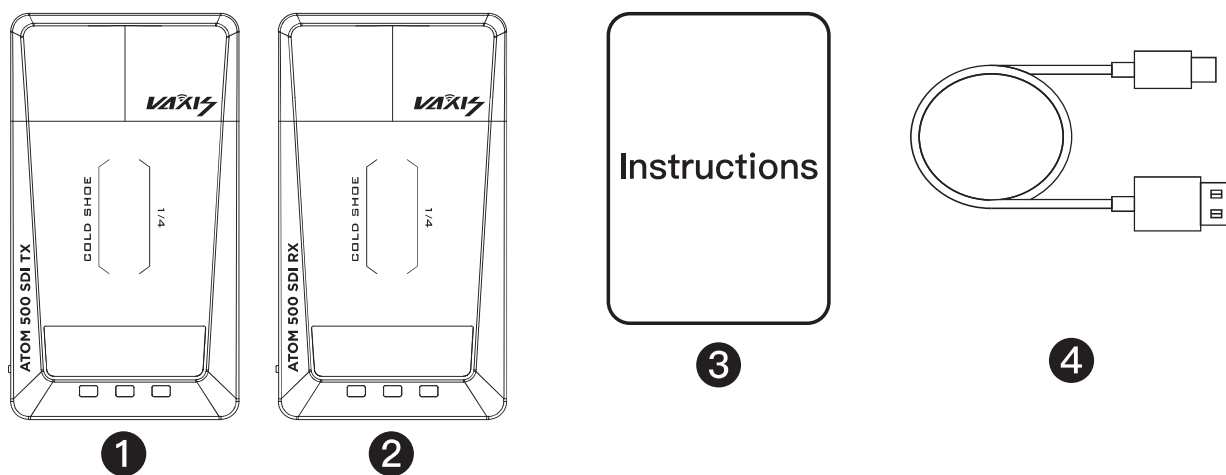

- ① Transmitter*1 ② Receiver*1 ③ User Manual ④ USB Type-C cable

Transmitter Interface

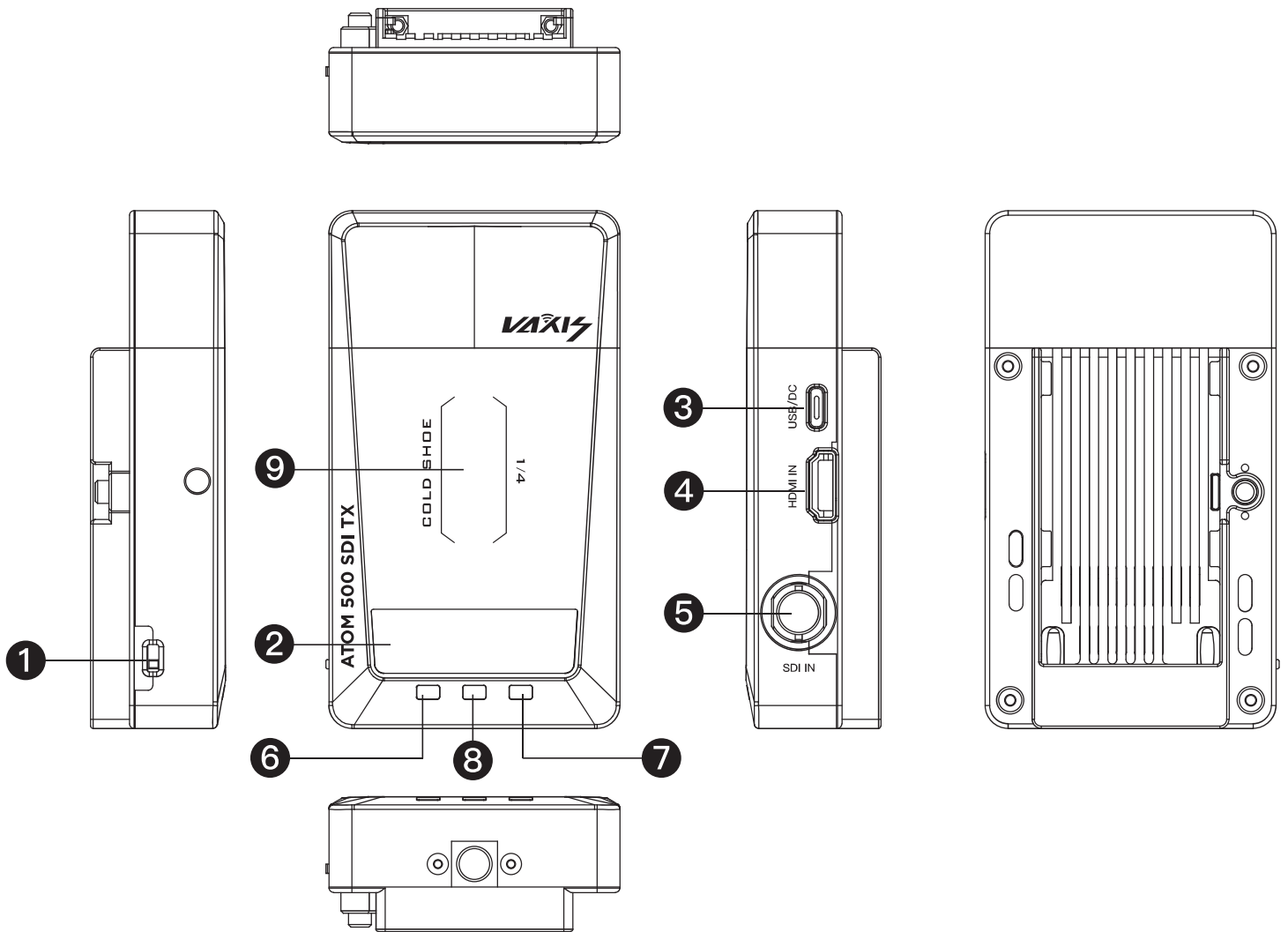

- 1 Power Switch
- 2 OLED display
- 3 USB interface
- 4 HDMI input
- 5 SDI input
- 6 Up
- 7 Down
- 8 Menu/OK
- 9 1/4 20 screw mount

Receiver interface

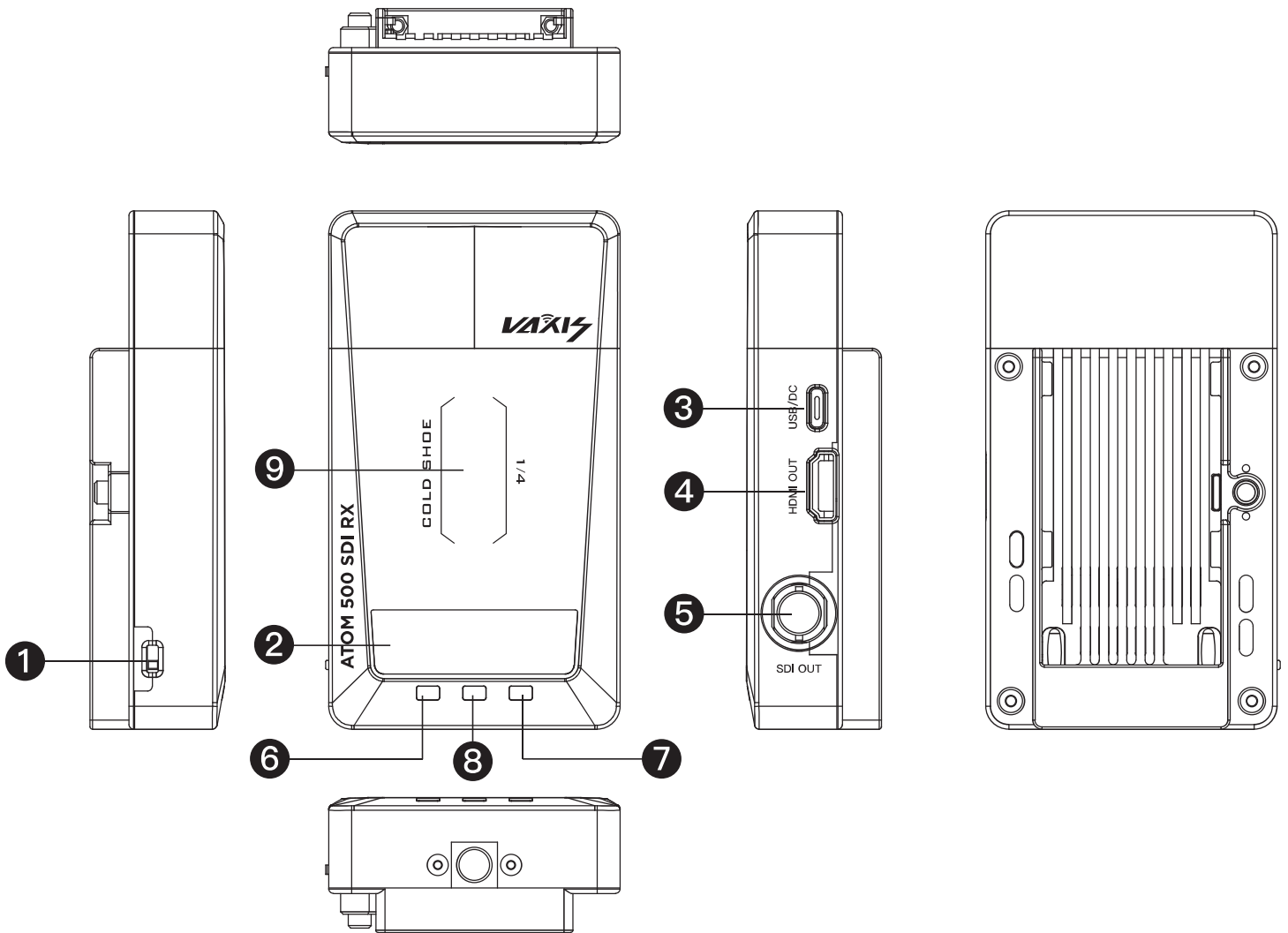

- 1 Power Switch
- 2 OLED display
- 3 USB interface
- 4 HDMI output
- 5 SDI output
- 6 Up
- 7 Down
- 8 Menu/OK
- 9 1/4 20 screw mount

OLED Display

Transmitter

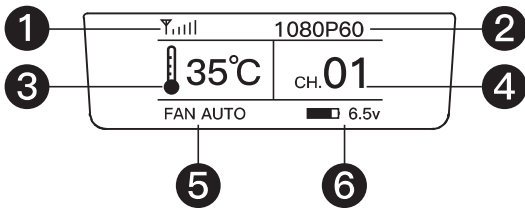

Receiver

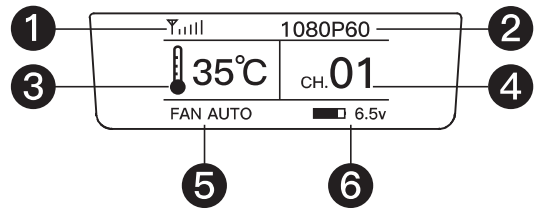

① Signal Strength ② Video Format

① Signal Strength ② Video Format

③ Temperature ④ Channel

③ Temperature ④ Channel

⑤ Fan Level ⑥ Battery Voltage

⑤ Fan Level ⑥ Battery Voltage

Operations Guide

Transmitter

Long press the menu button for approximately 3 seconds to enter the menu window to access the following features:

▶ ACCESSIBILITY
STEP
SCANNER
BACK

Function of each option:

PAIRING: It can pair with the RX. TX and RX need to operate simultaneously.

SSID: Display the SSID and Use for APP monitoring connected

PWD: display the PWD,Used for APP monitoring connected, PWD is changeable

CONNECTED RX: Current receiver connected quantity

APP: App monitoring off or on

Version: display current version

Return

Operations Guide

Receiver

Long press the menu button for approximately 3 seconds to enter the menu window to access the following features:

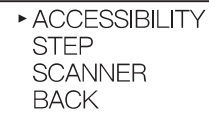

- ▶ ACCESSIBILITY
- STEP
- SCANNER
- BACK

Function of each option:

PAIRING: It can pair with the TX. TX and RX need to operate simultaneously.

OSD: OSD off or on

SSID: Display the SSID and Use for APP monitoring connected

PWD: display the PWD, Used for APP monitoring connected, PWD is changeable

PRIO: latency priority and image priority for choice

Version: display current version

Return

Channel change

Long press either the up or down button on the transmitter to change the channel, then press the OK button to confirm the selected channel. The receiver will change to the same channel as the transmitter automatically and simultaneously.

App's PWD change

Long press menu button to enter the menu window, click the down button to PWD<CURRENT> option then press the MENU button and change it to NEW; click the menu button to confirm change. It will take approximately 5–10 second to change successfully. (note: The password is able to change when the TX and RX is connecting)

Fan mode

Long press the up or down button approximately 3 seconds to enter the fan settings:

• fan low, fan high, fan auto, fan off.

App monitoring on or off mode

Long press the MENU button to enter the Menu window where you will be able to select on or off the APP monitoring.

APP connection and use

1.The application name is Vaxis Vision and is available in the App store / Play store



Scan the QR code, It will skip to app store automatically.

2.App connect:

1) Open the app (Vaxis vision) to choose Connect to Device

2) Long press TX menu button 3–5 seconds, then up and down to change

Change to SSID, type SSID (VX_A00001) into the APP.

3) Change the pwd<current>, There is 8 numbers password on below the PWD option.

Type the password in the APP, Click connect

Specification

	TX	RX
Interface	HDMI input/SDI input	HDMI output/SDI output
Voltage	5V DC	5V DC
Power	<6.5w	<6.5w
HDMI Input Video Format	720P@50/60Hz 1280*1024@60Hz 1080I@50/60Hz 1080P@24/25/30/50/60Hz	/
HDMI Output Video Format	/	720P@50/60Hz 1280*1024@60Hz 1080I@50/60Hz 1080P@24/25/30/50/60Hz
SDI Input Video Format	720P@50/60Hz 1080I@50/59.94/60Hz 1080P@23.98/24/25/29.97/30 50/59.94/60Hz 1080PSF23.98/24//25/29.97/30Hz	
SDI Output Video Format		720P@50/60Hz 1080I@50/59.94/60Hz 1080P@23.98/24/25/29.97 30/50/59.94/60Hz 1080PSF23.98/24/25/29.97/30Hz
Weight	170g	170g
Dimensions	113*63.5*20mm	113*63.5*20mm
Frequency	5GHz	
Transmission Power	17dbm	
Delay	80ms, 120ms in disturbing environment	
Rx sensitivity	-80dbm	

Troubleshooting

Connection issue

1. Check and make sure the power supply functions well on both the transmitter and the receiver.
2. Check if the battery level is enough, If the battery level is too low, Please change another battery.
3. Change to another channel to troubleshoot
4. Re-paring the device

Display issue

1. Please check if the video source is connected to the HDMI IN interface correctly.
2. Check if the OLED displays the video format. If not, check if the HDMI cable connected to transmitter is correctly linked with the camera and if the camera has the video output
3. Check if the format of the camera output interface is compatible with this system.

Video image stuck issue

1. Check if the HDMI IN/OUT cables are connected well.
2. Check the signal strength status to see if the signal strength is too weak Change the channel or shorten the distance between the devices.

APP connection issue

1. Make sure that the SSID and PWD are correct. Check if the PWD has been changed.
2. Make sure the APP is turned on.
3. Check the number of connected APP device. 1 transmitter can connect with/up to a maximum of 3 devices for wireless monitoring.

Firmware Upgrade

TX Firmware Upgrade

- 1) Copy the firmware upgrade file to a USB Flash Drive.
- 2) Power on TX, wait until frequency information appears.
- 3) Insert the USB flash drive into the OTG adapter and connect it to the TX's USB Type-C port.
- 4) The TX unit will automatically upgrade the firmware in 2–3 minutes. When the device finishes upgrading, the TX unit will restart automatically.

RX Firmware upgrade.

- 5) Copy the firmware upgrade file to a USB Flash Drive.
- 6) Power on RX, wait until frequency information appear.
- 7) Insert the USB flash drive into the OTG adapter and connect it to the RX's USB Type-C port.
- 8) The RX unit will automatically upgrade the firmware in 2–3 minutes. When the device finishes upgrading, the RX unit will restart automatically.

Note: Before copying the firmware upgrade file, make sure the USB flash drive is formatted to FAT32. Please check the version info to make sure the system upgraded successfully.

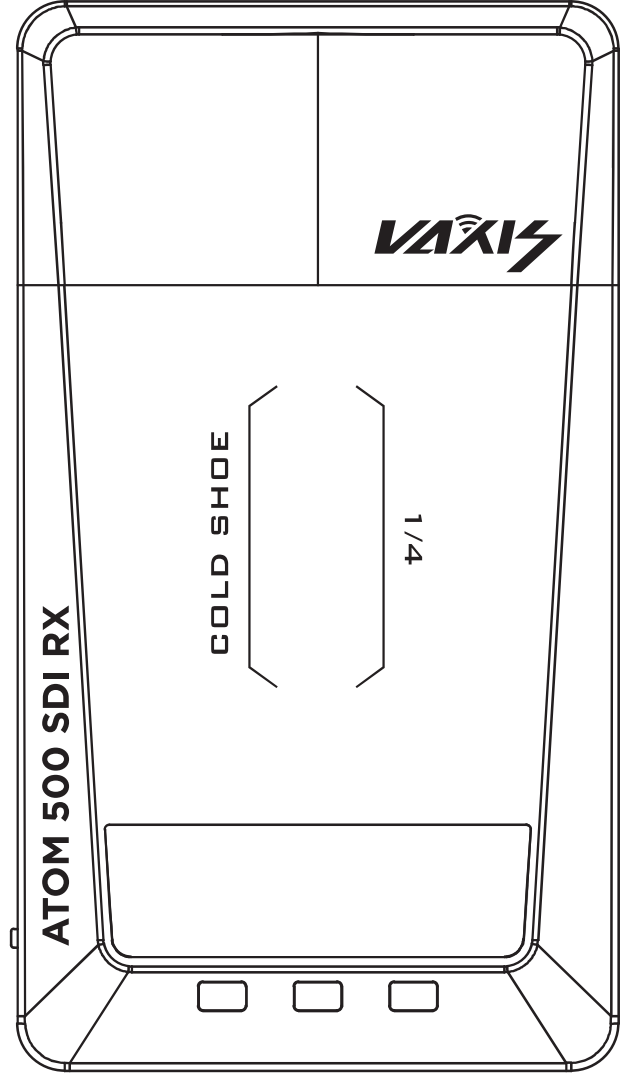
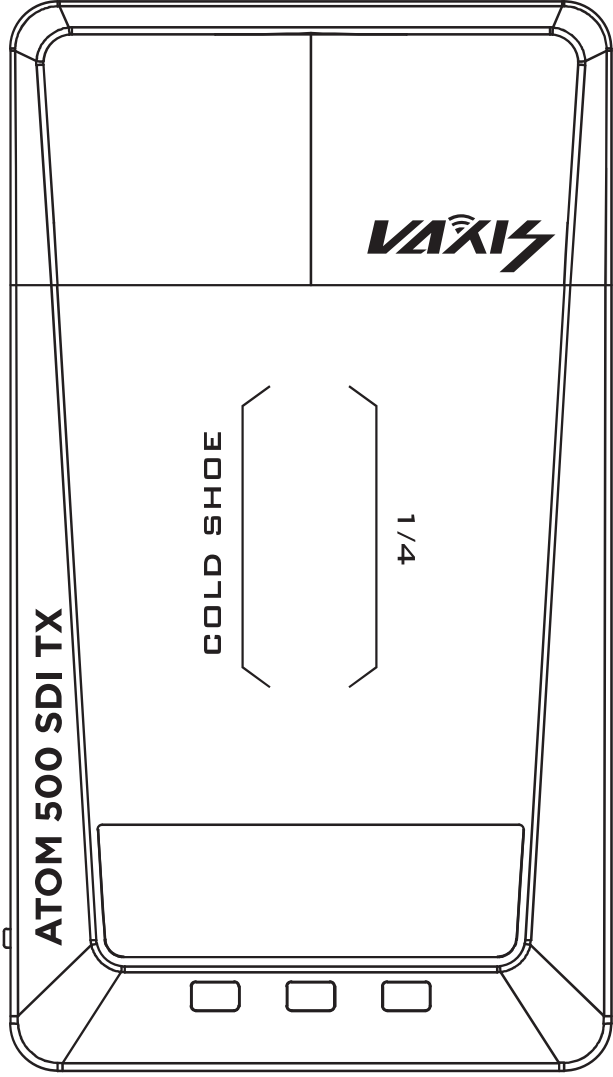

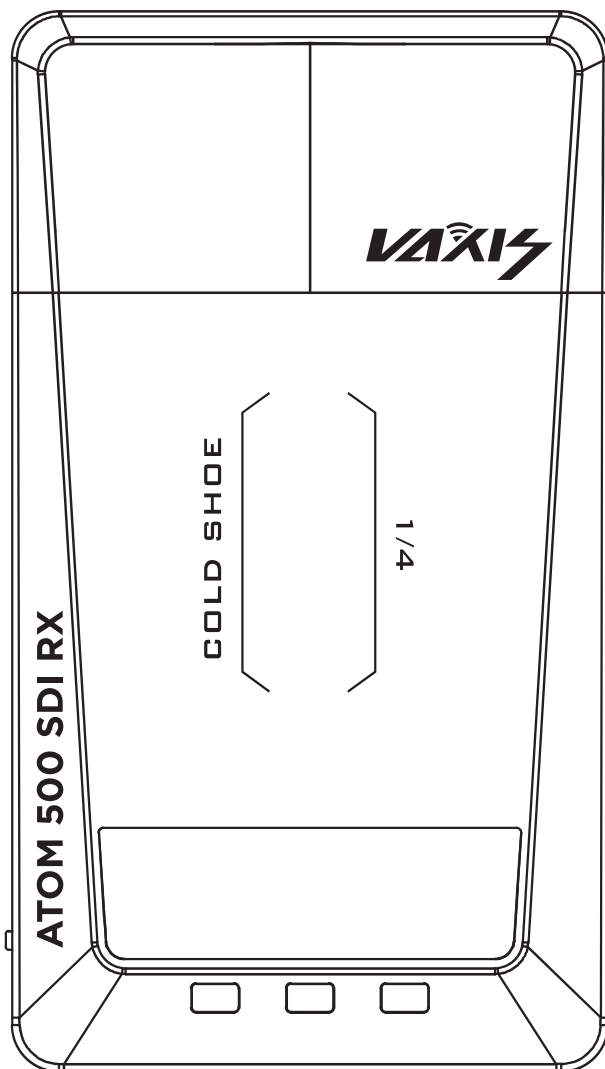
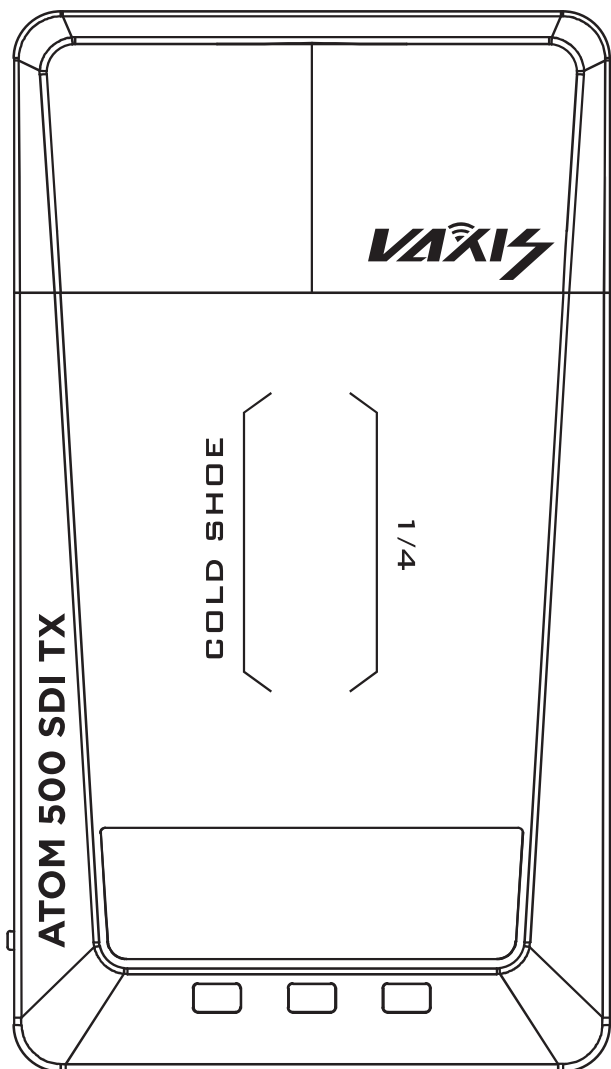

湖南光魔科技有限公司

HN Gmcine Technology Co., Ltd.

电话: +86400-014-7080



威固官方网站



微信公众号