

Vaxis Thor 800FT+ Wireless Transmission System

User manual

1. Cautions.....	1
2. About.....	2
3. Setting UP.....	5
4. Placement Guidelines and Best Practices.....	10
5. Operation instruction.....	11
6. Maintenance.....	17

1. Cautions

■ Logo and meaning

 Careful, warning, dangerous, Pay attend to following items.

■ Cautions

- Do not use this product in the extreme hot, cold, dusty or humid environments.
- Prevent friction with hard objects.
- Avoid the product falling down from a high place, or it may damage the hardware.
- The product is not water proofed. So do not get any liquid into the unit please.
- Do not dismantle, assemble or alter the product arbitrarily.

2. About

■ Product model and standard

The VAXIS THOR 800FT+ Wireless HDMI/SDI Transmission Suite utilize today's most advanced wireless video transmission technology, which can realize the broadcast-class and uncompressed 3G SDI/HDMI HD video signal transmitted with no compression and zero delay. The suite includes one transmitter and one receiver, where the transmitter provides a 3G/HD SDI input and a SDI output, and the receiver also provides a 3G/HD SDI output and a HDMI output. The wireless HD suite has 2 sword antennas in transmitter side, and 3 sword antennas in receiver side, and it can work in 5.1-5.9GHz frequency band and be flexibly software configured to licensed or ISM band of global different regions, which provides maximum 10 workable frequency channels, and supports maximum 8 sets working simultaneously. The wireless suite can accept wide range DC power input, which is suitable for many kinds of camera battery model. the industry class metal case and professional heat design would guarantee most robust reliability.

■ Main features:

- Wirelessly transmit visually lossless 1080p60 Video/Audio up to 200 meters.
- TX: SDI In & SDI In.
RX: SDI Out x1, HDMI Out x1.
- Built In HDMI/SDI Converter.
- Has 2 sword antennas in transmitter side, and 3sword antennas in receiver side.
- Mounting: Transmitter side with Sony NP-970 plate, Receiver side with V mount/ Gold mount plate.
- Support metadata, timecode, and start/stop flags from many camera manufacturers, including RED, ARRI, Canon, Sony, and Panasonic.
- USB firmware upgrade.
- All-metal housing, durable.
- Pure hardware connection; Plug and Play.

Technical Specifications

The following table presents the technical specifications for the Vaxis Thor 800FT+.

Specification	Parameter/Value	
Maximum Outdoor LOS range	200 - 250 meters	
Transmission Delay	Zero [Less than 1 msec.]	
Radio Frequency	20MHz or 40 MHz	
Channel Selection	Automatic frequency selection [AFS] Manual frequency selection is also available via PC tool	
Video Formats	1080p24/23.98, 1080p60/59.94, 1080p/50, 1080i60/59.94, 1080i50, 1080psf30/29.97,	
Multicast Mode	1080psf24/25/23.98, 720p60/59.94, 720p50, 576p60 Up to 4 receivers with no delay or quality degradation. [Requiring extra Monitor Unit(s)]	
OSD Support	Supports distance measurements, link quality and battery status.	
Encryption	AES-128 & RSA 1024 for key exchange	
Operating Temperature	0-45° Celsius	
Regulation	Chinese regulation supported	
	Camera Unit	Monitor Unit
Video Interface	SDI	SDI HDMI Type A
Antenna Connectors	2dBi external SMA (x2)	2dBi external SMA (x3)
Power Connector	Lemo input	Lemo input
Power Input	6-28V	6-28V
Dimensions (mm)	117 x 83 x 23	147 x 101 x 28
Weight	230 grams	410 grams

Supported Resolutions

The following table lists the video resolutions supported by Vaxis Thor 800FT+.

Video Format Timings	Format Name	40MHz	20MHz
1280 x 720p @ 50Hz	720p	Yes	N/A
1280 x 720p @ 59.94/60Hz		Yes	N/A
1920 x 1080i @ 50Hz	1080i	Yes	N/A
1920 x 1080i @ 59.94/60Hz		Yes	N/A
1920 x 1080p @ 23.98/24Hz	1080p	Yes	N/A
1920 x 1080p @ 29.97/30Hz		Yes	N/A
1920 x 1080p @ 50Hz		Yes	N/A
1920 x 1080p @ 59.94/60Hz		Yes	N/A
PsF		Yes	N/A

3. Setting UP

■ Setting Up the Thor 800FT+ Transmitter

This section describes how to set up the Thor 800FT+ Transmitter. We highly recommend that the accessories and cables you use are of the highest quality.



IMPORTANT

IMPORTANT! For optimal system performance, carefully read and then implement the guidelines listed in [Placement Recommendations for Camera and Monitor Units](#).

To set up the Thor 800FT+ Transmitter:

1. Attach the transmitter to the camera, taking the placement recommendations into account.
2. Connect the two provided sword antennas to the two transmitter's antenna ports, as shown below:

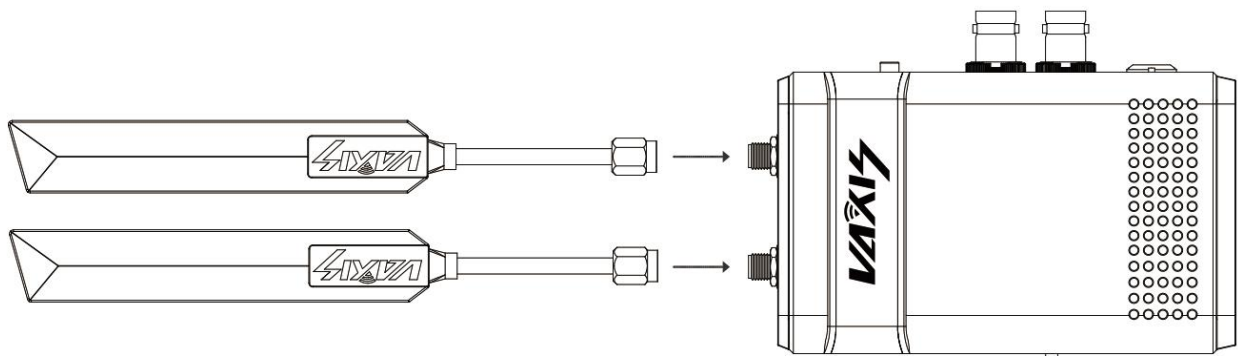

3. Connect the **SDI cable** from the **SDI IN** port on the transmitter, The other side of this cable goes into the camera.
4. Connect the **Power cable** to the power port on the transmitter. The other side of this cable goes to the battery.
5. The transmitter automatically connects with the powered on receiver that are paired with this transmitter.
A connection is established between the transmitter and receiver regardless of whether video is transmitted on the wireless link:
 - If video is transmitting, the receiver display the video.
 - If video is not transmitting, the receiver display the message: Video signal not detected. The transmitter's video and transmission status is indicated by its LEDs, as described below.

LED Behavior

The Thor 800FT+ Receiver features three LED indicators: a Power LED, a Video LED and a Signal LED. In normal operating conditions, the Power LED shows a constant green color, and the two other LEDs show a constant blue color.

When all three LED indicators are blinking quickly, a system error has been detected. In this case, contact Vaxis support.

The behaviors of each individual LED are described in the tables below.

Transmitter - Power LED

On (Green)	The transmitter is powered on.
Off	No power is being supplied to the transmitter.
Blinks Quickly	Indicates a system error.

Transmitter – Video LED

Solid	The video signal from the camera is locked, meaning that it is being correctly received by the Transmitter from the camera. (This does not necessarily indicate that a link exists.)
Blinks Slowly	The video from the camera is not locked, meaning that the Transmitter is not receiving the video from the camera.
Blinks Quickly	The camera is transmitting a video resolution that is not supported by the Transmitter. (For a list of supported resolutions.)

Transmitter – Signal LED

Solid	A link has been established to the Receiver, meaning that video is being transmitted to it (all of the receivers are powered on and in range).
Blinks Quickly	Registration is in progress, or the Transmitter has gone out of range of a Receiver and is searching for it.
Blinks Slowly	The Transmitter is establishing a link with a Receiver.
Blinks Very Slowly	The Transmitter is searching for an available frequency on which to transmit. Note: This may take up to 70 seconds when working outdoors in Japan.
Off	No broadcasting is occurring.

■ Setting Up the Receiver of Vaxis Thor 800FT+

This section describes how to set up the Thor 800FT+ receiver. You may set up the receiver using SDI, HDMI, or both. We highly recommend that the accessories and cables you use are of the highest quality.

IMPORTANT! For optimal system performance, carefully read and then implement the guidelines listed in [Placement Recommendations for transmitter and receiver](#).

To set up the Thor 800FT+ Receiver:

1. Screw on the 3 provided antennas to the receiver' 3 connectors , as shown below:

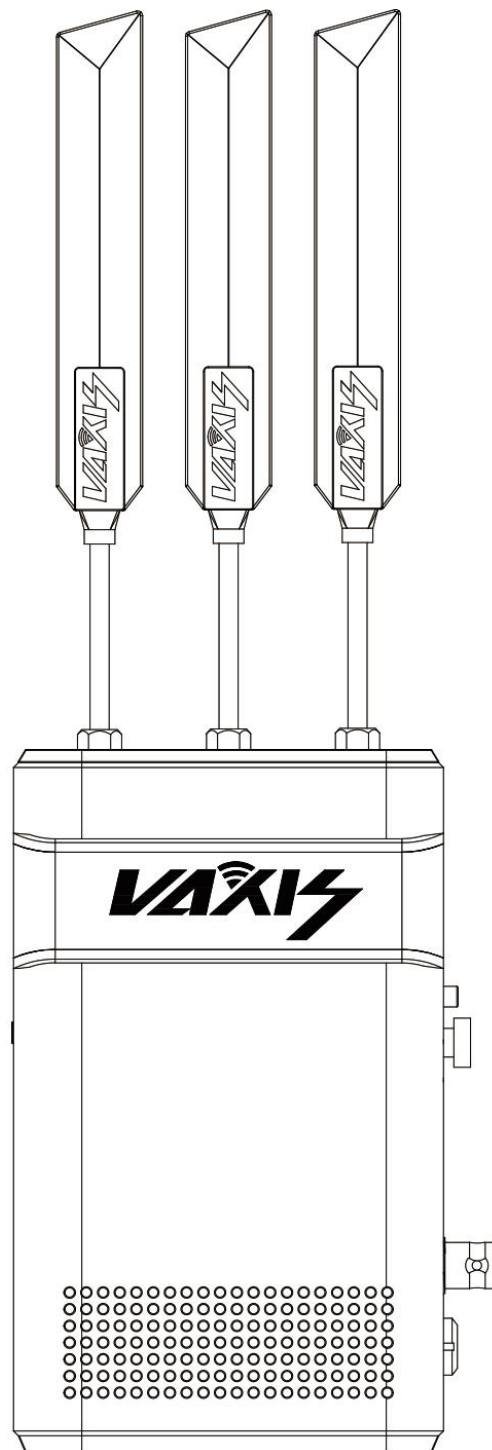

2. Enable display of the received video via SDI by connecting a **standard SDI cable** from the Receiver's **SDI port** to the monitor's **SDI port**.

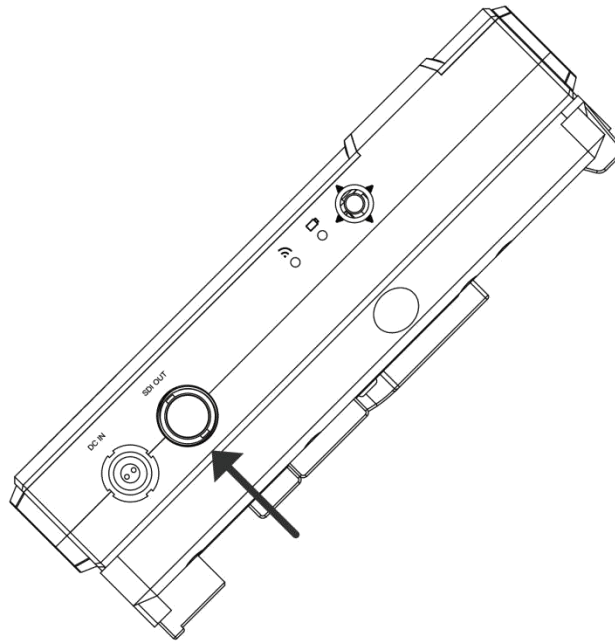

3. Enable display of the received video via HDMI by connecting a **standard HDMI cable** from the Receiver's **HDMI port** to the monitor's **HDMI port**.

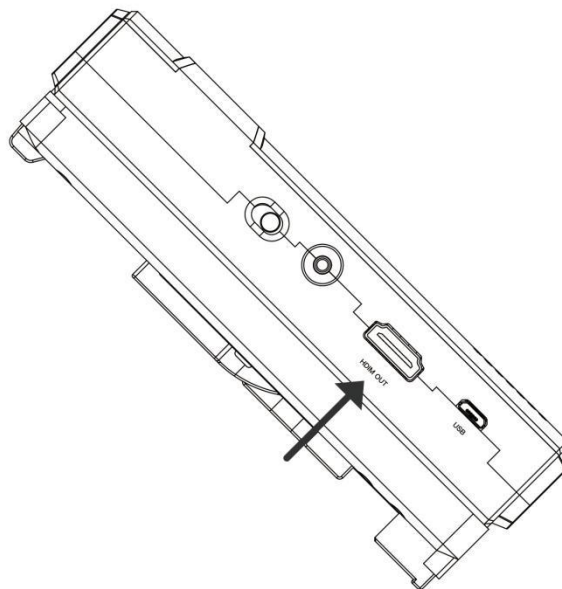

4. Connect the power cable to the Lemo connector on the Receiver, and connect the other end to a power source.

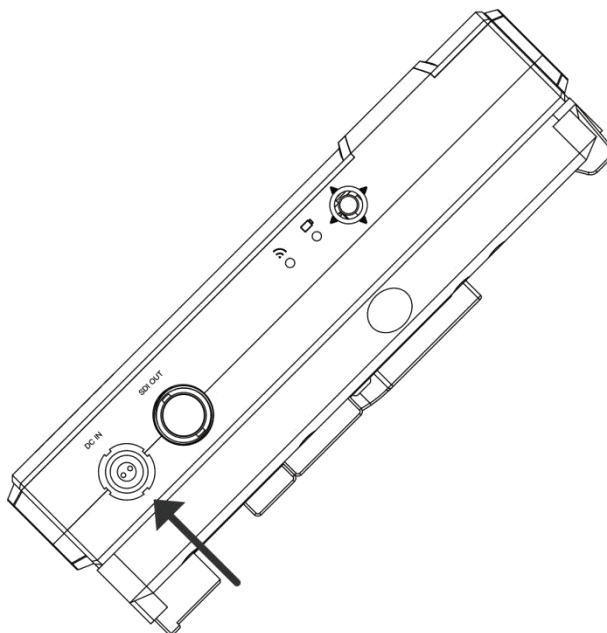

5. Verify that both LEDs on the Receiver light up, as described in the tables below.

LED Behavior

The Thor 800FT+ Receiver features two LED indicators: a Video LED and a Signal LED. In normal operating conditions, both LEDs show a constant green color. No power (or low power) is indicated by the LEDs turning off.

When the indicators in both LEDs are blinking quickly, a system error has been detected. In this case, contact VAXIS support.

The behaviors of each individual LED are described in the tables below.

Receiver – Video LED

Solid	The video signal from the camera is locked (i.e., the signal is being received from the Transmitter.)
Blinks Slowly	The video signal from the camera is not locked.
Blinks Quickly	The camera is transmitting a video resolution that is not supported. For a list of supported resolutions.

Receiver – Signal LED

Solid	A link has been established to the Receiver.
Blinks Quickly	Registration is in progress, or the Receiver has gone out of range.
Blinks Slowly	The Transmitter is establishing a link with the Receiver.

4. Placement Guidelines and Best Practices

■ Maintaining Line of Sight (LOS)

In order to obtain maximal range from the Vaxis Thor 800FT+, it is necessary to maintain proper line of sight (LOS) between the Transmitter and the Receiver. Adhere to the following recommendations to achieve best LOS:

- To ensure optimal RF conditions, place both the Transmitter and the Receiver as high as possible.
- Remember that any obstacle between the Transmitter and the Receiver might reduce range. Avoid positioning your units in places where there is object interference (e.g., a wall).
- If placement in the vicinity of an obstacle cannot be avoided, keep in mind that different types of ob-stacles have different effects on the range. For example, a brick wall will cause more interference than a thin drywall.

For more placement guidelines and best practices, refer to [Placement Recommendations for Transmitter and Receiver](#) .

■ Placement Recommendations for Camera and Monitor Units

In order to obtain maximal performance from the StudioLink system, always adhere to the following placement recommendations:

- Ensure proper line of sight (LOS) between the Transmitter and the Receiver. For details, refer to [Maintaining Line of Sight \(LOS\)](#).
- To achieve maximal range, position all antennas in an upright position.
- Avoid or remove any interfering obstacles, especially metal parts (such as the body of the camera).
- Maintain a distance of one meter between Transmitters.
- Maintain a distance of at least one meter between Receivers.
- Mount the Receivers on tripods at a height of 1.5 meters.

The following figure shows an example of proper placement of the Transmitter and the Receiver:

5. Vaxis Thor 800FT+ Operational Instructions

■ Working with On Screen Display (OSD) Functions

When OSD functionality is enabled, you can view additional data displayed on the monitor attached to the Receiver, and monitor system parameters from the OSD menus. The following data is overlaid on the video received from the Camera Unit:

- Basic system parameters, such as current link quality and video resolution. For details, refer to [Acti-vating the Information Bar](#).
- Various alerts and notifications. For more information, refer to [Alert and System Messages](#).

You can perform the following activities from the OSD menus:

- Check data related to the Thor 800FT+ you are working with (e.g., firmware version). For details, refer to [Viewing Paired Unit Parameters](#).
- Pair additional Monitor Units with the Camera Unit. For more information, refer to [Multicasting to Multiple Receivers](#).

Activate and manipulate the On Screen Display features using the OSD joystick on the Monitor Unit. For more details on operating the joystick, refer to [Using the OSD Joystick](#).

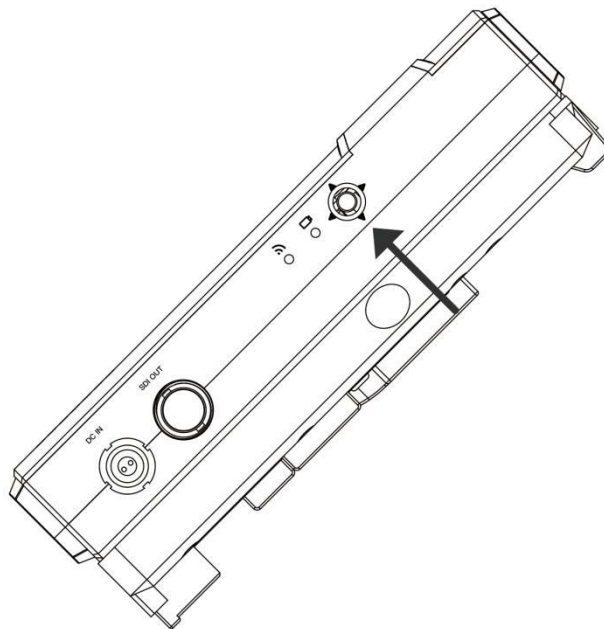

Using the OSD Joystick

The OSD joystick is made up of four direction selectors (Up, Down, Left and Right) and a confirmation button in the center. Enable On Screen Display by pressing the confirmation button. The **Main Menu** screen is displayed on the monitor.

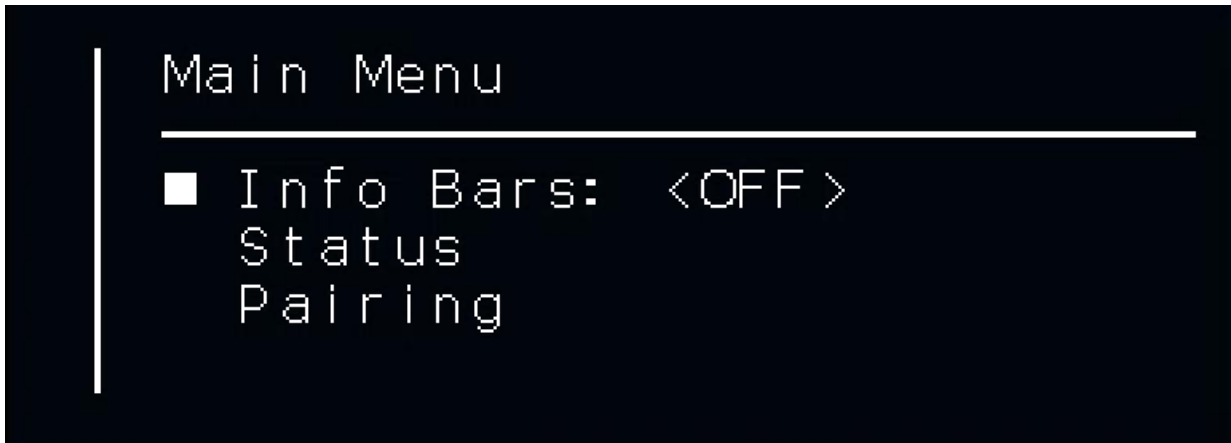

Navigate through the menus using the direction selectors:



- **Down:** Goes to the next menu or the next menu option.
- **Up:** Goes to the previous menu or the previous menu option.
- **Right:** Enters the options list of the currently selected menu.
- **Left:** Exits the options list of the currently selected menu.

Activating the Information Bar

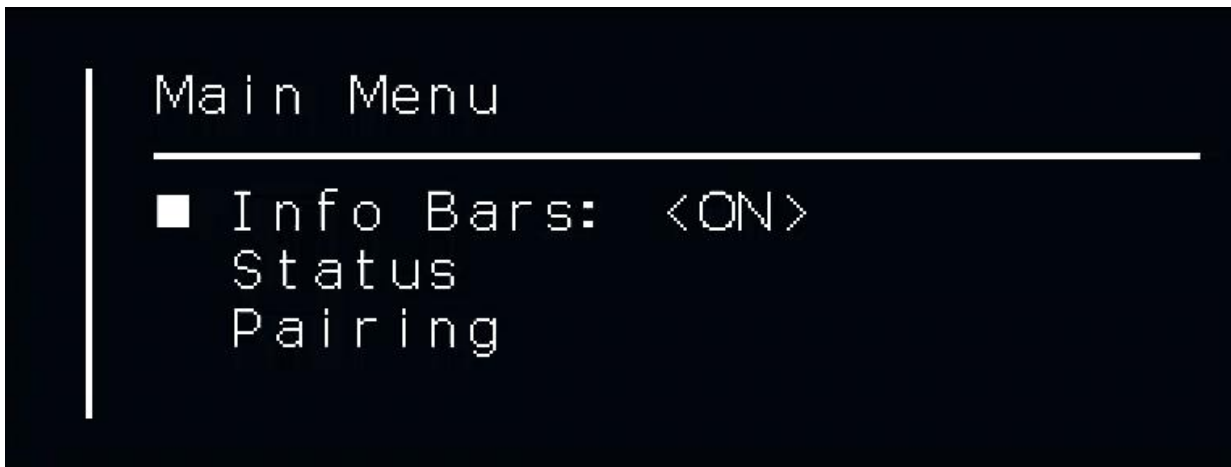
The **Info Bars** menu option determines whether or not the Information Bar is overlaid on the video received from the Transmitter. Toggle the option between **<OFF>** and **<ON>** by pressing the Right direction selector on the OSD joystick.

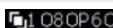

When the **Info Bars** option is **<ON>**, the following information is displayed in the Information Bar:

Icon	Description
	Transmitter to Receiver video signal strength.
	Distance of the Transmitter from the Receiver (in meters).
	Video resolution captured by the camera.

For example:



Viewing Unit Parameters

The **Status** menu lists information related to the Transmitter and Receiver you are working with.

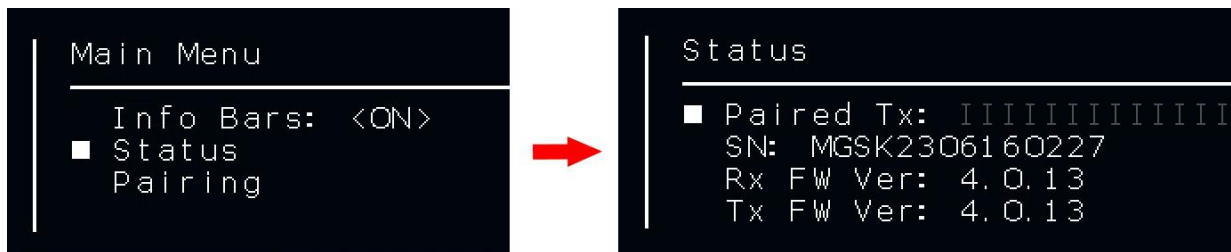

The following parameters are displayed:

- **Paired Tx:** The name of the Transmitter with which the Receiver is paired.
- **SN:** Serial number of the paired Transmitter .
- **Rx FW Ver:** Firmware version of the Receiver.
- **Tx FW Ver:** Firmware version of the Transmitter.



IMPORTANT

For the system to perform as expected, the firmware version in the Receiver and the Transmitter must be the same.

Alert and System Messages

The tables below describe messages that may appear on the monitor connected to the Receiver's SDI or HDMI port.

Alert Messages – Overlaid on Video During Link

These alert messages may be displayed on top of the live video:

Alert	Description
Out of Range	A link still exists, but Transmitter is too far from the Receiver. This message appears regardless of whether OSD display is enabled. When the Transmitter is within range, the video signal is automatically reacquired.

Approached Range Limit	This alert is displayed for 30 seconds, from the moment the Transmitter has been detected as out of range until the Out of Range warning is displayed. The message is a warning that the video signal is about to be lost. This message appears only when OSD display is enabled.
Video Signal Not Detected	A link has been established between the Transmitter and the Receiver, but no video signal has been detected. This message appears regardless of whether OSD display is enabled.

System Messages – No Link

These system messages may appear when no live video is displayed:

Alert	Description
Searching for Transmitter	This message is displayed until a link is established. This may occur when the Transmitter is out of range or unavailable, or when the Receiver has been removed from its list of paired devices.
Pairing in Progress	This message is displayed while the Transmitter is pairing with a Receiver. For a detailed description of the pairing process, refer to Multicasting to Multiple Monitor Units .

Multicasting to Multiple Receivers

A single Transmitter can transmit video downlink to up to 4 Receivers. This is called *multicasting*. The following procedure describes how to pair an additional Receiver with the same Transmitter.



NOTE

1. The Transmitter and Receiver provided in the same box are preconfigured to automatically search for and connect to each other. Therefore, there is no need to perform this procedure on the Transmitter / Receiver delivered in the same box.
2. Register one Receiver at a time to each Transmitter.

Pairing Additional Receivers with a Transmitter

To pair an additional Receiver with a Transmitter:

1. Set up the additional Receiver, as described in [Setting Up the Thor 800FT+ Receiver](#). The Receiver must be placed between one and ten meters from the Transmitter. To enable optimal reception, each Receiver must be placed at least a few meters away from other Receivers.

After setting up the additional Receiver, the following message is displayed on the monitor connected to the Receiver's SDI or HDMI port:

"Receiver not registered to Transmitter."

2. From the Receiver, activate the OSD display. Navigate to the **Pairing** menu, and select **Start Pairing**.

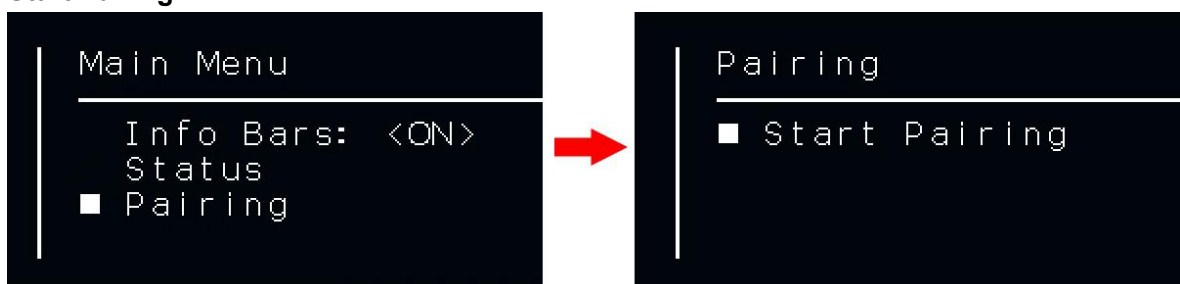



NOTE

For more information about using the OSD joystick, refer to [Working with OSD Functions](#).

The **Signal**  **LED** starts blinking, and the following message is displayed on the monitor connected to the Receiver:

"Please activate registration on Transmitter."

3. Power on the Transmitter with which to pair this Receiver. It is assumed that the Transmitter has already been set up, as described in [Setting Up the Thor 800FT+ Transmitter](#).
4. Press and hold the Transmitter's **Reg** button for approximately five seconds, until the Signal LED starts blinking.

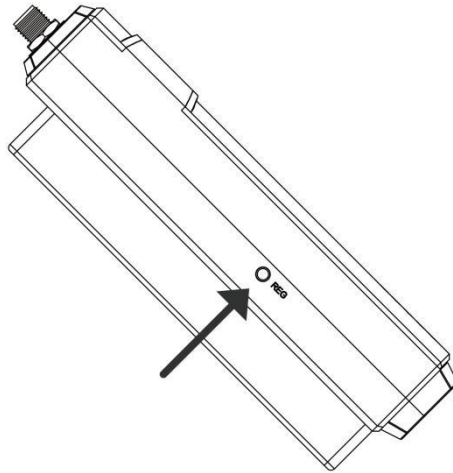

The following message is then displayed on the monitor connected to the Receiver:

"Pairing in progress."

After a while, the monitor connected to the Receiver should display the video received from the Transmitter.

6. Maintenance

■ Storage conditions

Products storage temperature should be $-20^{\circ}\text{C}\sim 60^{\circ}\text{C}$. For long time storage requirement, please use original carbon boxes, and avoid from high humid, acid base or dusty place.

■ Maintenance

Warning

To ensure your safety, please choose well-known brand DC batteries, and guarantee suitable work conditions that battery manual mentioned.

